

# AE-PS01 Heavy-Duty Dough Roller



**Perfect crusts every time! Designed for Busy Cooks! Looks like hand-rolled dough!**  
 Pizza ▪ Focaccia ▪ Roti ▪ Calzones ▪ Dessert Pie Crusts ▪ Flour Tortillas ▪ Pita bread ▪ Pasta

American Eagle: Value, Quality, and Reliability

**Let us help with your restaurant operation's efficiency!**

The American Eagle® AE-PS01 dough roller is part of our comprehensive line of heavy-duty, high-quality machines. Our dough rollers help pizzeria and restaurant operators save time and training costs. Within seconds, employees can make uniform product without having expertise in hand tossing, slapping, or rolling a dough ball. They are a time-saving solution for restaurants challenged with high volume or employee turnover.

**Standard Features**

- All-In-Front ergonomic designs saves space
- 500-700 pieces/hour productivity and easy maintenance
- Heat-treated steel alloy gear mechanism for durability
- Small footprint can be suitable for countertops or carts
- Powerful 1 H.P. motor, permanently lubricated ball bearings
- Push button control offers one-touch convenience
- Adjustable handle controls output thickness with easy turn
- Easy two-pass system requires virtually no training
- Approvals: NSF No. 8, ETL, CSA, CE

**Standard Warranty**

- 1 year parts and ninety days labor
- Must register with American Eagle



**Specifications Summary (See reverse for details)**

Motor	Voltage	Net Weight	Overall Dimensions W x D x H	Ship Weight	Shipping Dimensions W x D x H
1 H.P.	115V/60Hz/1P	298 Lbs	32.3" x 27.6" x 31.9"	386 Lbs	34" x 29" x 39"

**We offer unbeatable value pricing everyday. Contact an American Eagle representative today!**

## Specifications

*Due to continuous product improvement, specifications may change without notice*

<p><b>Motor:</b>          1 HP &amp; 8 Amps. Motor overload protection w/ reset button. Totally enclosed to prevent oil leaks or food contamination.</p> <p><b>Transmission:</b>          Easy-to-maintain gear driven transmission. Sealed ball bearings are permanently lubricated in grease for worry-free maintenance.</p> <p><b>Voltage:</b>          115V /60 Hz / 1Ph (8 Amps)</p> <p><b>Cord &amp; Plug:</b>          6-foot flexible 3-wire cord and plug fits into grounded receptacle.</p> <p><b>On/Off Switch:</b>          Easy to find red and green buttons located on front of machine.</p> <p><b>Construction:</b>          Heavy-duty cast iron frame has a smooth, seamless design. Sanitary, stainless steel trays and PVC fiber conveyer belts are designed for extra resiliency.</p>	<p><b>Safety</b>          Machine automatically shuts off if safety bar is lifted. Machine automatically shuts off if rear cover is removed.</p> <p><b>Double-Pass System</b>          1. Flattened dough ball passes through the top chute.          2. Elongated dough comes out and is fed back via metal tray          3. Finished product comes out for further food application.</p> <p><b>Adjustable Thickness</b>          Side handle quickly adjusts to the precise thickness you require. Handle operates between 0.04in (1mm) and 0.7in (18mm)</p> <p><b>Maximum Capacity</b>          Pizza diameter up to 18.0"</p> <p><b>Roller:</b>          18-inch length can make crusts up to 18" in diameter. 3.5-inch roller diameter.</p>	<p><b>Shipping Information:</b>          Freight Class: 85          Net Weight: 297lbs. (135 kgs.)          Shipping Weight: 386 lbs.( 175 kgs.)          Shipping Dimensions:          35.7"W x 32.2"D x 38.04"H (91cm x 82 cm x 97cm)          Crates are affixed to a skid (pallet). The weight and dimensions of this skid are included above and may vary from shipment to shipment.</p> <p><b>Machine Dimensions:</b>          Overall Width = 32.3" (82 cm)          Overall Depth = 27.6" (70 cm)          Overall Height = 31.9" (81 cm)</p> <p><b>Enamel Finish:</b>          Powder white paint. Heat treated to resist rust, scratches, and dents.</p> <p><b>Rear Cover:</b> Rear cover lifts up to facilitate cleaning. To maintain, regularly clear the belts and mechanism of flour or other crumbs.</p>
--	--	---

In metric centimeters:

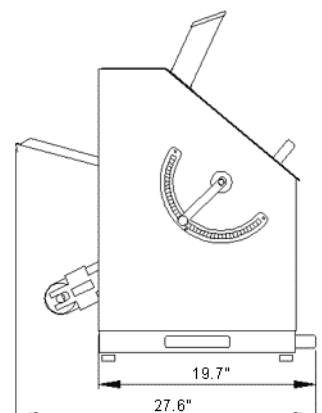
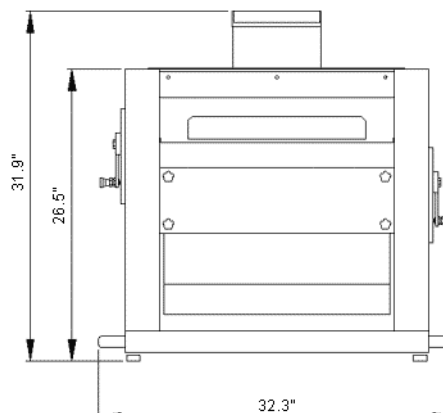
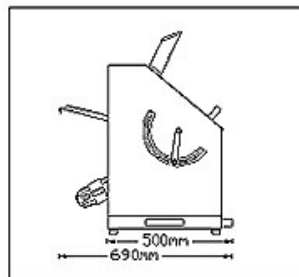
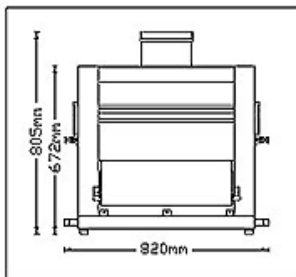

AE-PS01 American Eagle Bench Dough Roller