

AE-100K Spiral Mixer

250 Qt Bowl, 350 Lbs of Dough

American Eagle spiral mixers meet every baker's challenge: high-capacity, high-efficiency machines at an affordable price. Their exceptional reliability make it ideal for busy cooks by decreasing mixing times and maintenance. This versatile mixer makes a variety of dough from bagels to pizza.

The machine of choice for busy chefs

- Shorter mixing times
- Higher output
- Consistent results

Spiral Mixing Technology: The Secret to Better dough

Why do European artisan breads taste better? The most important thing besides your recipe is the way the dough is handled. Used for decades in European-style bakeries, spiral mixers can imitate hand-kneading and rolling motions. The gentle coordinated movement of bowl and agitator controls blending while preventing overdeveloped dough. The dough stays cooler, mixes in less time, and has better consistency.

Features

- Heavy-duty agitator is 25% thicker than industry leader
- Handles heavier pizza & bagel dough with ease
- Reversible mixing action makes better dough, and in less time
- Heavy-duty construction and powerful two-motor system
- Easy maintenance and time-saving versatility
- Heat treated enamel coating resists scratches, rust, and dents
- Mounted on castors for extra mobility and easy maintenance
- Overload relay protects motor and transmission
- Approvals: NSF No. 8, ETL, CE, CSA

Standard Accessories

- Two 60 min timers automatically shift between high and low speed
- Stainless steel extra durable spiral agitator
- Stainless steel stationary bowl
- Stainless steel safety guard
 - Locking mechanism prevents operation when lifted
 - See through to bowl guard

Standard Warranty

- 1 year parts and ninety days labor
- Bagel and pizza dough rated at low speeds only
Use in high speed voids warranty
- Must register with American Eagle



American Eagle: Value, Quality, and Reliability

Other Available Sizes:

- AE-1220 40 Qt Spiral Mixer
- AE-3050 80 Qt Spiral Mixer
- AE-4065 100 Qt Spiral Mixer
- AE-5080 125 Qt Spiral Mixer
- Special Order: AE-100K 250 Qt Spiral Mixers

Contact an American Eagle representative today to find the right sized mixer for your operation!



3557 S. Halsted St, Chicago, Illinois 60609
800-836-5756 ▪ sales@ameagle.biz

AE-100K Spiral Mixer

250 Qt Bowl, 350 Lbs of Dough

Specifications

Due to continuous product improvement, specifications may change without notice

<p><u>Agitator (Arm) Specifications</u> Spiral Arm Motor: 15HP and overload protection w/ reset button. 4 Pole (Low speed) 8 Pole (High speed)</p> <p>Arm Agitator Speeds: Low-121 rpm, High-243 rpm Manual (continuous) mixing</p> <p>Transmission: Drive belt made from heavy-duty, durable PVC fiber. The pulley system reduces stress on individual belts and adds years of useful life to your machine.</p> <p><u>Bowl Specifications</u> Capacity: 253 Quarts (240 Liters) 100% high polish stainless steel stationary bowl.</p> <p>Motor: 5 HP. Moves the bowl in coordinated fashion to arm.</p> <p>Bowl Guard: See-through stainless steel guard stands up to the toughest challenges. Interlocking mechanism prevents mixing until guard is fully closed</p>	<p><u>Other Specifications</u> Quality Materials: High polish stainless steel meets food industry sanitation needs. Non-porous food surfaces easily wipe off after use.</p> <p>Frame: Made from heavy-duty cast iron. Coated with NSF approved enamel paint. Baked at high temperatures to resist rust, scratches, and dents.</p> <p>Timer: Each speed is automatically controlled by an accurate sixty minute digital timer, ensuring consistency. Machine can also operate with timer disabled.</p> <p>Speed Mode: The machine must be turned off before shifting speed mode. Push red stop button, select High or Low Speed to turn on again.</p> <p>Transport System: Mounted castors (wheels) allow the machine to be moved easily for occasional cleaning or maintenance. A front lever controls the locked or unlocked position of the machine.</p>	<p><u>Electrical Specifications</u> Voltages: 220V /60 Hz / 3Ph Permissible voltage range: 198 Volts to 242 Volts (+/- 10%)</p> <p>Cord: 6 ft. flexible three wire cord. Electrical connections must be made by qualified personnel in accordance with applicable codes & regulations.</p> <p><u>Shipping Information:</u> Shipping Weight: Freight Class: 85 Net Weight: 2,536 lbs. (1150 kgs.) Shipping Weight: 2,867lbs.(1300 kgs.)</p> <p>Crates are affixed to a skid (pallet). The weight of this skid is included above and may vary from shipment to shipment.</p> <p>Shipping Dimensions: 67"W x 42"D x 41"H (170.2cm x 106.7cm x 104.1cm)</p>
-----------------------------------------------------------------------------------------------------------------------------------------------------------------------------------------------------------------------------------------------------------------------------------------------------------------------------------------------------------------------------------------------------------------------------------------------------------------------------------------------------------------------------------------------------------------------------------------------------------------------------------------------------------------------------------------------------------------------------------------------------------------------------------------------------------------------------------------------------------------------------------------------------------	-----------------------------------------------------------------------------------------------------------------------------------------------------------------------------------------------------------------------------------------------------------------------------------------------------------------------------------------------------------------------------------------------------------------------------------------------------------------------------------------------------------------------------------------------------------------------------------------------------------------------------------------------------------------------------------------------------------------------------------------------------------------------------------------------------------------------------------------------------------------------------------------------------------	-------------------------------------------------------------------------------------------------------------------------------------------------------------------------------------------------------------------------------------------------------------------------------------------------------------------------------------------------------------------------------------------------------------------------------------------------------------------------------------------------------------------------------------------------------------------------------------------------------------------------------------------------------------------------------------------------------------------------------------------------------------------------------------------------------------------------

Specifications Summary

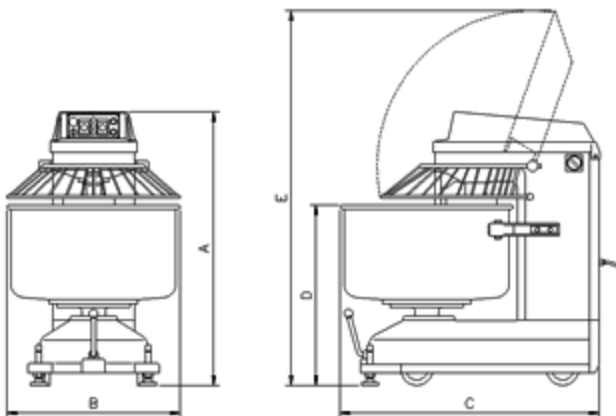

Dimensions		
A	35.8 in	91 cm
B	62.2	158
C	37.4	95
D	32.2	82
E	79.53	202

Bread Dough Capacity

Flour Dough
210 Lbs 350 Lbs

Bagel Dough Capacity

Flour Dough
166 Lbs 245 Lbs