



# AMERICAN EAGLE® FOOD MACHINERY, INC.

3557 S. Halsted St, Chicago, Illinois 60609  
800-836-5756 ▪ sales@ameagle.biz

## AE-VC30 Series Vegetable Cutter & Prep Machine

### Ideal for :

- Salad or Fresh Menu
- Supermarket Deli
- Fast Food Restaurant
- Professional Chef

American Eagle® AE-VC30 vegetable preparation machines are part of our comprehensive line of heavy-duty, high-quality machines. Their exceptional reliability and attractive, compact designs make them ideal for open kitchens. Their versatility makes any kind of food preparation work easy.

### Standard Features

- Ergonomically correct 45 degree angle for easy reach
- Dual chamber system suited for a variety of fruits & vegetables
- Powerful 550 watt (¾ H.P.) motor for continuous operation
- Permanently lubricated gear and belt drive
- Easy, One-touch button operation
- Compact size and long 7 ft cord ideal for countertop
- Heavy-duty design and durable materials
- Easy maintenance and time-saving versatility
- Approvals: NSF No. 8, ETL, CE

### Standard Accessories

- Disc holder for safe & easy disc removal
- Food Pusher
- Stainless steel shredding disc in 3mm and 7mm
- Stainless steel slicer on flexible enhanced nylon disc in 2mm, 4mm

### Deluxe Accessories

- Additional 4mm shredder disc
- 2-Pc Cubing/Dicing Kit available in 4 sizes
- Julienne Cutting Disc in 3 sizes
- 2 Pc French Fry Cutting Kit in 2 sizes

### Standard Warranty

- 1 year parts and ninety days labor
- Must mail warranty registration to American Eagle

### Specifications Summary (see reverse for detailed)

Model	Productivity	Blade Speed	Motor	Voltage V/Hz/Ph	Dimensions (Overall LxWxH)	Ship Weight
AE-VC30	661 Lbs/Hour	270 rpm/min	550 Watts	115/60/1	23.4 x 10.6 x 19.6in	55 (49.6 net)

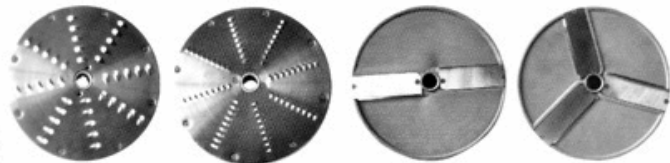



American Eagle: Value, Quality, and Reliability

### Perfect, Crisp, and Professional Cuts Every Time.

- Dice and Cube
- Julienne
- Slice
- French Fry Cut
- Shred
- Grate

### Specifications

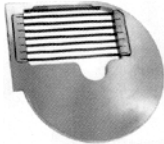
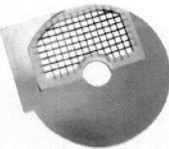
*Due to continuous product improvement, specifications may change without notice*

Standard Features	Optional Cutting Plates	Dimensions																																							
<p><b>Quality Materials &amp; Design:</b> Durable stainless steel &amp; aluminum alloy body. Stainless steel knife blades are sanitary and easy to maintain. Seamless and waterproof design operates even in damp conditions.</p> <p><b>Motor:</b> Powerful 550 Watts (3/4 HP) motor designed for heavy duty commercial use. Overload protection w/ reset button protects internal gears and belt.</p> <p><b>Safety:</b> Rubber legs prevent the machine from moving during operation. Cutoff switch stops machine operation when cover is open, or when operator comes in contact with rotating elements.</p> <p><b>Electrical:</b> 115 Volts /60 Hz /1Ph 7 foot (185mm) flexible 3-wire cord and plug fits into grounded receptacle.</p> <p><b>Cycle Speed:</b> 270 RPM's</p> <p><b>Capacity:</b> 661 Lbs (300 Kgs)/hr</p>	<p><b>Top Cutter Disc</b> (use with Dice or French Fry Cut) AE-VC30/T10: 10mm Cutter A AE-VC30/T8: 8 mm Cutter A</p>  <p><b>Bottom Finishing Disc</b> (use w/ Top Cutter Plate)</p> <p><b>French Fry Cut Plates</b> AE-VC30/B10 10x10mm AE-VC30/B8 8x8 mm</p> <p><b>Dicing Plates</b> AE-VC30/D20 20x20x10 (8) mm AE-VC30/D12 12x12x10 (8) mm AE-VC30/D10 10x10x10 (8) mm AE-VC30/D8 8 x 8 x 10 (8) mm</p>   <p><b>Julienne Discs (Individual)</b> AE-VC30/JD2.5 2.5x2.5mm AE-VC30/JD4 4 x 4 mm AE-VC30/JD10 10 x 10mm</p>  <p><b>Shredding Disc (Individual)</b> AE-VC30/S4 4mm</p> 	<p><b>AE-VC30 Dimensions</b> Net weight: 49.6. lbs. (22.5 Kgs.) Shipping weight: 55 lbs. (26 Kgs.)</p> <p><b>Box Dimensions:</b> 22"W x 11.4"D x 22"H (56cm x 29cm x 56cm)</p> <p><b>Installation Dimensions:</b> See diagrams below</p> <table border="1" data-bbox="1149 961 1464 1396"> <thead> <tr> <th></th> <th>inches</th> <th>cm</th> </tr> </thead> <tbody> <tr><td>A</td><td>6.8</td><td>17.2</td></tr> <tr><td>B</td><td>6.7</td><td>16.9</td></tr> <tr><td>C</td><td>19.6</td><td>49.8</td></tr> <tr><td>D</td><td>23.4</td><td>59.5</td></tr> <tr><td>E</td><td>15.0</td><td>38.2</td></tr> <tr><td>F</td><td>8.5</td><td>21.5</td></tr> <tr><td>G</td><td>1.5</td><td>3.9</td></tr> <tr><td>H</td><td>8.1</td><td>20.6</td></tr> <tr><td>I</td><td>10.0</td><td>25.5</td></tr> <tr><td>J</td><td>8.9</td><td>22.6</td></tr> <tr><td>K</td><td>10.6</td><td>26.8</td></tr> <tr><td>L</td><td>5.7</td><td>14.5</td></tr> </tbody> </table>		inches	cm	A	6.8	17.2	B	6.7	16.9	C	19.6	49.8	D	23.4	59.5	E	15.0	38.2	F	8.5	21.5	G	1.5	3.9	H	8.1	20.6	I	10.0	25.5	J	8.9	22.6	K	10.6	26.8	L	5.7	14.5
	inches	cm																																							
A	6.8	17.2																																							
B	6.7	16.9																																							
C	19.6	49.8																																							
D	23.4	59.5																																							
E	15.0	38.2																																							
F	8.5	21.5																																							
G	1.5	3.9																																							
H	8.1	20.6																																							
I	10.0	25.5																																							
J	8.9	22.6																																							
K	10.6	26.8																																							
L	5.7	14.5																																							

### Installation Diagrams

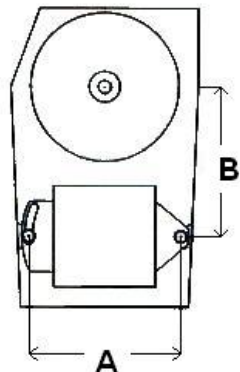

Bottom View

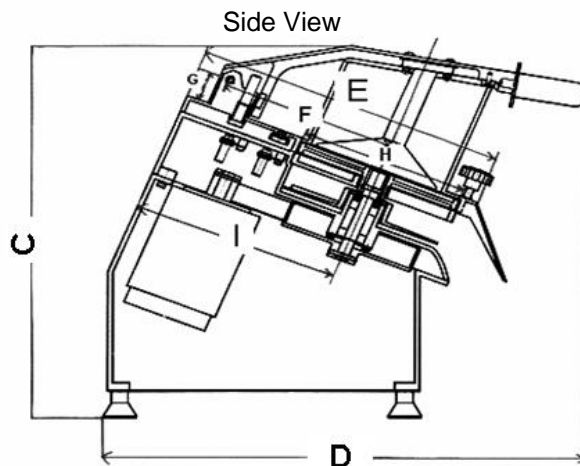

Side View

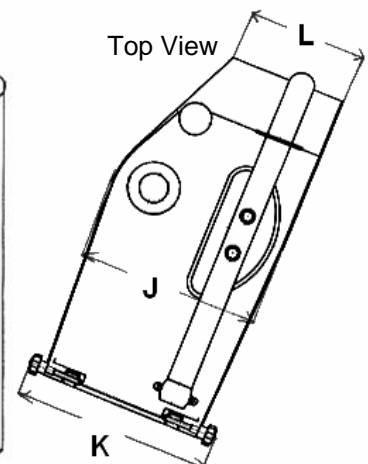

Top View